

3 Meet your Document System

Introduction

The system is a folding and inserting system for processing mail easily. The system:

- feeds documents
- folds the documents
- inserts the documents into envelopes
- seals the envelopes
- stacks the envelopes

Automatic monitoring ensures the correct number of documents per envelope. The system can be operated by means of a user friendly interface. The settings of the system (type of documents, type of envelopes and the type of fold) are recorded in so called jobs. These jobs can be created by the operator.

Operator and supervisor

You can use the system as operator and as supervisor. The supervisor has access to more settings than the operator. You can switch from operator to supervisor in every screen. When you switch to supervisor, you see immediately the result: extra tabs appear for the advanced settings. Also the side menu contains extra functions.

System Overview

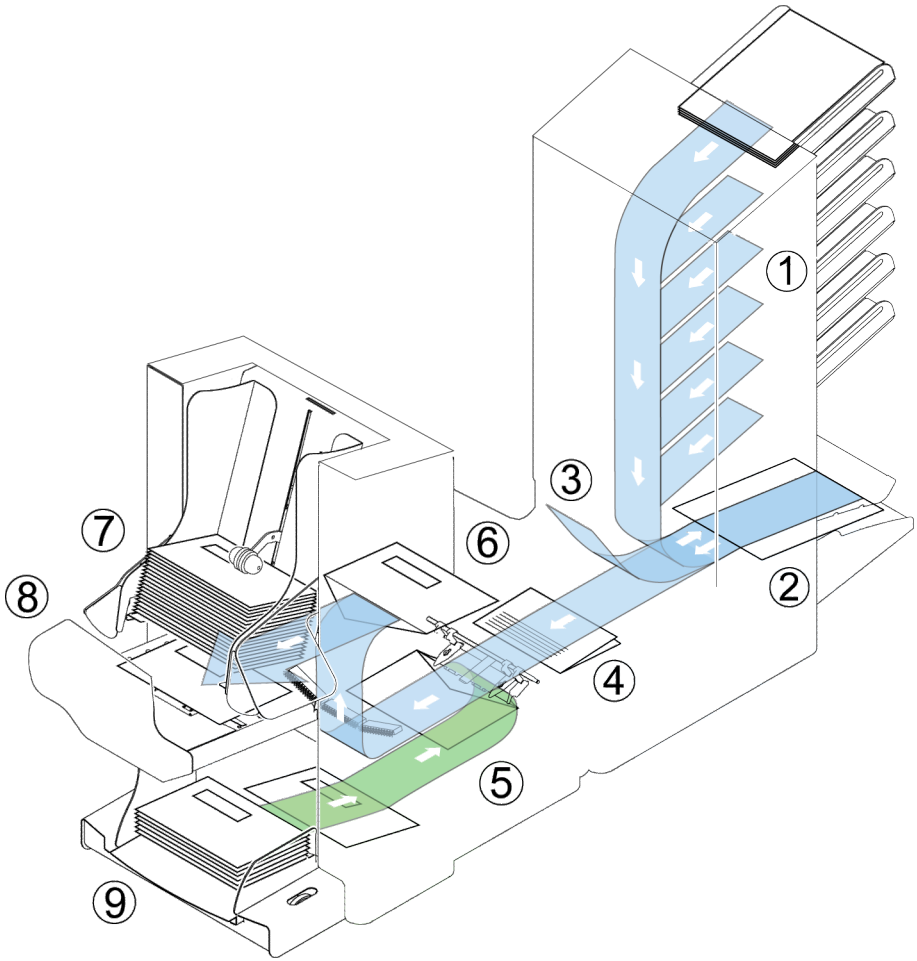

Works Cited:

FP. "FPi 6700." User Guide, 2 Feb. 2020.
download.fp-usa.com/product_docs/FPi-6700/FPi-6700-User-Guide-V2-Feb-2-2020.pdf.

The figure shows an overview of the system.

Document Feeders (1)

The Feeder is the feeding part of the system. There are two types of feeders: the automatic and the special feeder. The automatic feeder does not require any adjustments for the separation. From a feeder you can feed one or more documents (multi feed). The feeders have a double feed control (DFC). DFC detects if more documents are fed instead of one.

You can link feeders. This means that two feeders can be linked as pairs. When the first feeder is empty, the system switches to the other feeder. Meanwhile the empty feeder can be refilled without stopping the system.

The upper automatic feeder is equipped with a 'daily mail' function. You can use this feeder to process sets of documents that you cannot process automatically (stapled documents and sets with varying thickness).

Collating Area (2)

All documents of a document set are collated and aligned in the collating area.

Divert Area (3)

The IntelliDeck automatically throws out incorrect sets of documents. In this way the system does not need to stop. Correct sets will be transported to the powerFold unit.

Folder Unit (4)

The fold unit folds the documents. The following fold types are possible (see [Terminology](#)):

- No fold
- V-fold
- C-fold
- Z-fold
- Double V-fold

Inserter (5)

After the documents are folded, the documents are transported to the inserter. The inserter inserts the documents into a waiting envelope. The inserter seals the envelope or not, depending on the settings. Automatic monitoring ensures the correct number of inserts per envelope.

Present on Deck (6)

The documents inserted (or not) can leave the inserter from the upper unit (present on deck). This can occur when:

- Clearing the machine;
- Making a test set;
- Depending on the reading code.

Stacker (7)

The documents inserted (or not) are transported to the stacker depending on the programmed job. The stacker automatically stacks inserted documents.

Side exit (8)

The documents inserted are transported to the side exit depending on the programmed job. The side exit can be used for sorting and stacking of documents into the catch tray as well as transporting to the optional conveyor belt or franking/mailing machine.

Envelope Hopper (9)

Envelopes that are placed on a stack by the user, are fed one by one into the system by the envelope hopper.

Operating Controls

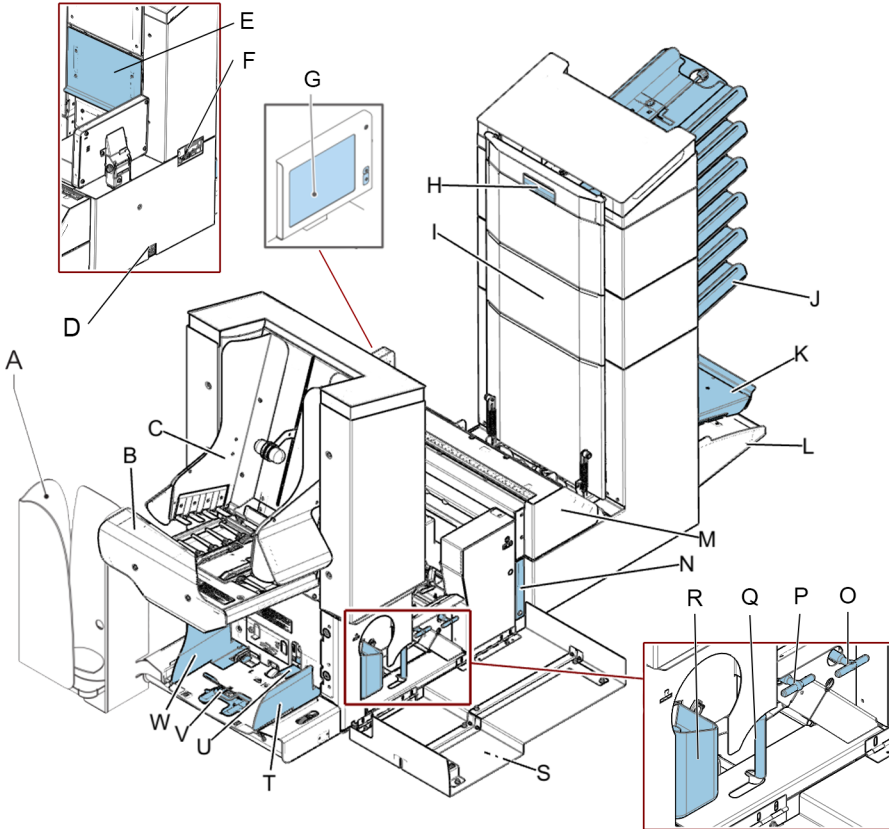

- A** - catch tray (optional)
- B** - side exit / stacker unit
- C** - side guides stacker
- D** - power inlet, power switch
- E** - unlocking lever for upper unit
- F** - USB (2x), RS232 and ethernet
- G** - control panel
- H** - hand grip vertical transport cover
- I** - vertical transport
- J** - document feed tray
- K** - collator arm
- L** - divert area
- M** - folder unit
- N** - locking handle folder unit
- O** - handle for manual transport of the envelope
- P** - handle for manual transport of the mail set
- Q** - unlocking handle for rollers envelope track
- R** - sealing liquid reservoir
- S** - side cover (opened)
- T** - thumb wheel for side guide adjustment
- U** - side guides envelope feed tray
- V** - flap for envelope separation adjustment
- W** - envelope support

Control Panel



On/Off (B): The touch sensitive button in the upper right corner of the display switches the system on or off. If the system is not used for one hour, the system switches off to safe power.

Status LED (C): A status LED indicates the state of the machine, a green LED indicates that the system is switched on, a blinking red LED indicates the system is switched off.



The display is a capacitive touch screen. To avoid permanent damage of the display, do not use sharp objects to operate the display.



To clean the display use a dry lint-free or microfiber cloth. If water is necessary to clean the screen, you should make your microfiber cloth slightly damp instead of putting the water directly on your screen. Never use large amounts of water, harsh chemicals, abrasive cloths or paper towels to clean the display.

Power Up

To start up the system:

1. Connect the system to the mains power supply.



You can severely damage the machine if it is connected to the incorrect mains voltage. Before plugging in the machine, check if the local voltage is the same as the voltage mentioned on the type plate **(A)**.

- Press the on/off button next to the display **B**.

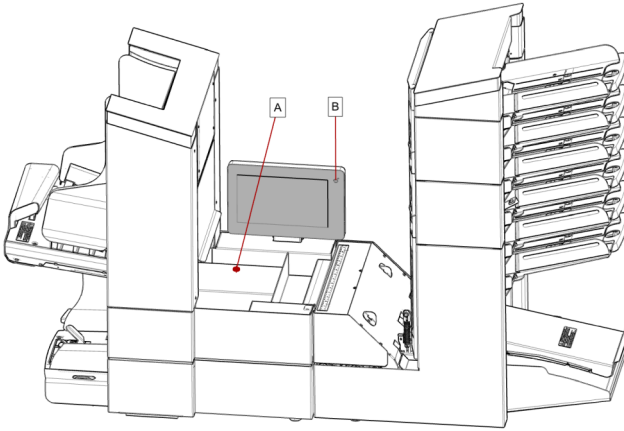

In case the system is unresponsive or fails to switch off, press and hold the touch sensitive power button for 10 seconds to switch off the system.

- The touch screen shows the Job list screen.

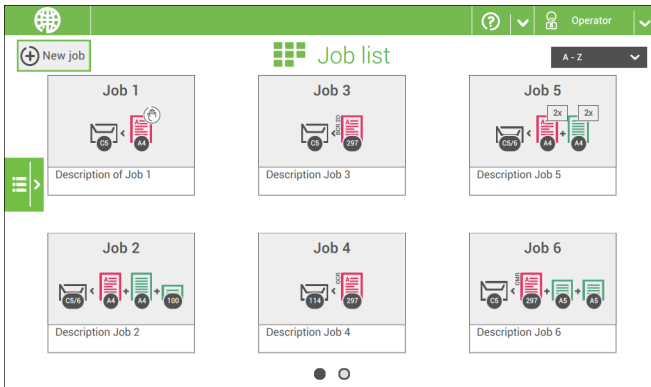

How to Operate the Touch Screen

You can operate the touch screen like a tablet:

- **Tap** : touch and release the screen with your finger.
- **Swipe**: touch the screen, hold it and move your finger(s) left, right, up or down.
- **Tap and hold**: touch the screen with your finger and hold it for two seconds.
- **Pinch in/out**: to zoom in/out.

Tap

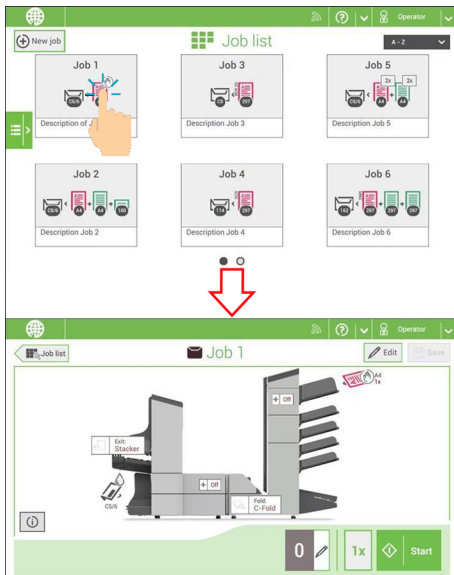

Swipe

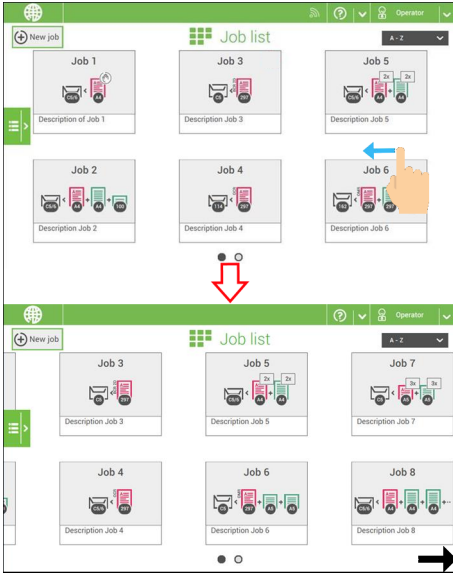

Tap and hold

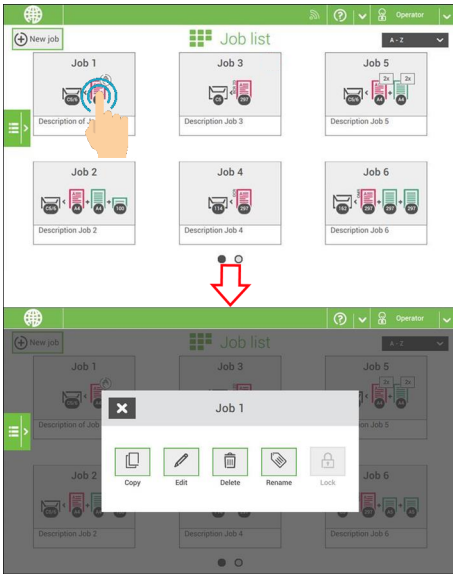

Pinch in/out

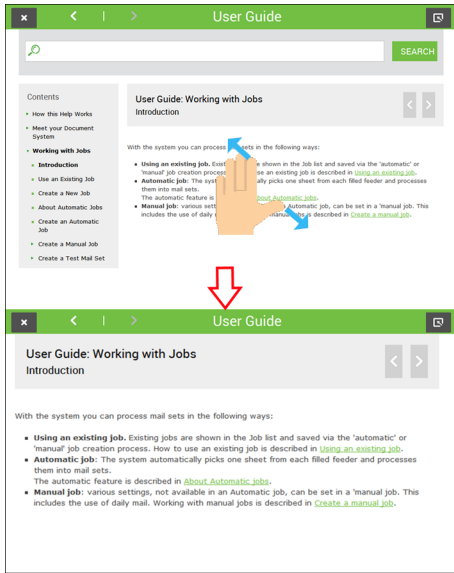

Use a Web Browser

You can open a web browser in the user interface of the system. Use the web browser as follows:

1. Tap on the icon in the upper left corner of the screen to open the Web browser.



2. You can tap or swipe to navigate through web sites.
Use the keyboard to type in the navigation bar of the browser or within web sites.



If you work with a special keyboard for your language, you can switch the keyboard back to the English version to type e.g. a web address. (see [Localisation](#) on page 82)

3. Tap the Minimize button to keep the Web Browser active.

4. Tap the Close button in the upper left corner of the screen to close the web browser.

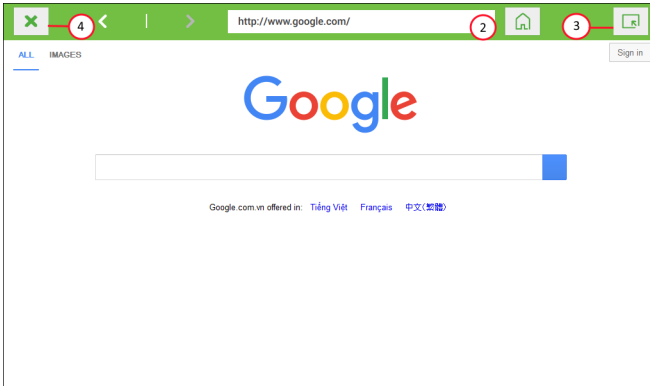

What is a Job?

If you have to process a lot of mail sets of the same type (for example bills), you can save the settings to a 'job'. The next time you just select the job and immediately start without defining any settings.

The following settings are saved in a job:

- Envelope type/size;
- Sealing on/off;
- Which document feeders should be used, how many documents should be fed from each feeder and document height for each feeder;
- Feeder linking on/off;
- If BREs or insert cards should be included;
- Address position;
- Fold settings;
- Double feed control settings;
- Reading settings (option);
- Exit select settings;
- Batch Counter, defining the number of mail sets that the job must process. The job will automatically stop processing when this number is reached.

Job List

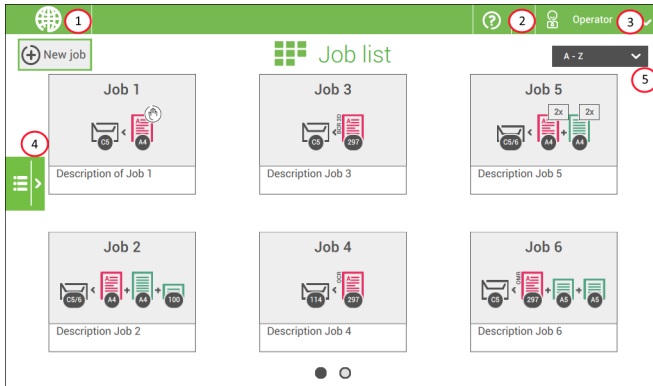

When you start up the system, the 'Job list' menu appears.

1. [Open a web browser](#) on page 15
2. [Help menu](#) on page 3
3. Login, see [Introduction](#) on page 6
4. Side menu
5. Job list sorting

The side menu contains the settings menu (see [Settings menu operator](#) on page 75). When you are logged in as supervisor, the settings menu is extended with advanced settings (see [Settings menu supervisor](#) on page 77).

If you want more information on a job, select the job. With the **[Job list]** button you get back to the home menu.

See also: [Working with Jobs](#) on page 26.

Job Overview

3

English

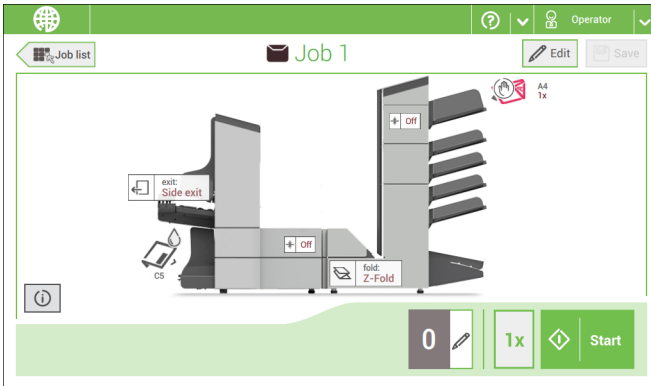

If you want more information on a job, select the job in the Job List menu.

The touch screen shows the following information of the selected job:

- Job name
- Job settings (for example the document and envelope type)
- How to load envelopes and documents for this job
- The number of envelopes that have been processed with this job







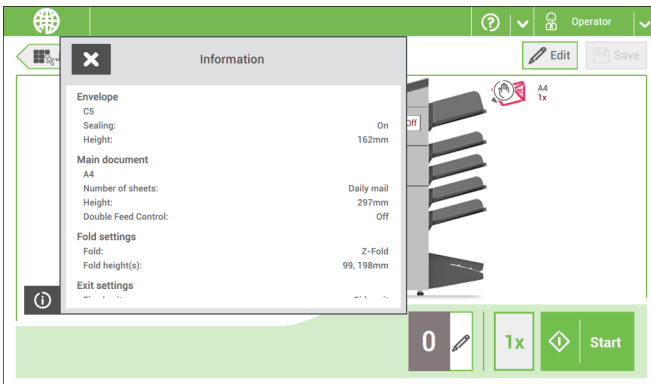







In this screen you can change the following settings:











- Counter settings (see [Change the counter settings](#))
- Job settings (see [Editing a job](#))
- Move documents between feeders (see [Change to an other feeder tray](#))
- Link feeders (see [Link feeder trays](#))
- Start the job or run a test run (see [Performing a test run](#))

If you tap the **[i]** button a summary of all information of the job is listed.



The following is a list of symbols or icons and their descriptions.

	<p>Main document. Shows the correct document orientation; A is the address.</p>		<p>Document with reading Shows the correct document orientation; A is the address.</p>
	<p>Daily mail Feature to manually insert mail-sets one by one into the system.</p>		<p>Enclosure</p>
	<p>Notification Next to this symbol, a message appears, e.g. Sealing liquid low, empty feeder.</p>		<p>Wired LAN connected Network connection is available via a network cable connection.</p>
	<p>Wireless LAN connected Network connection via Wi-Fi is available.</p>		<p>Wired LAN not connected Network connection is not available via a network cable connection.</p>
	<p>Wireless LAN connected, no internet Network connection via Wi-Fi is available, network is not connected to internet. Check with your network administrator.</p>		<p>Wireless LAN not connected Network connection via Wi-Fi is not connected or out of range.</p>
	<p>Envelope, sealing on Envelopes will be sealed. The symbol shows the correct envelope orientation.</p>		<p>Envelope sealing off Envelopes will not be sealed. The symbol shows the correct envelope orientation. When sealing is off, the flap of the envelope is closed but not moistened.</p>
	<p>Feeder linking Linking means that when one feeder is empty, the system automatically starts feeding documents from the other feeder. This symbol at the feeders shows if the feeders are linked.</p>		<p>Change feeder trays Possibility to change from one feeder tray to another.</p>

	<p>Dfc/mail set thickness detection Double feed control and/or mail set thickness detection has been set to 'off'. By default the dfc/mail set thickness detection will be set to 'on' and the icon will not be shown.</p>		<p>Fold type This icon shows what kind of fold type has been set.</p>
	<p>Exit setting This icon shows what kind of exit setting has been set.</p>		<p>Counter setting Shows on what number the counter has been set.</p>
	<p>1x button After tapping this button the system will create an example mail set.</p>		<p>Start button Tapping this button runs the job.</p>
	<p>Job list button After tapping this button the job list screen will be shown.</p>		<p>Stop button Button to stop the system The current mail set will be completed and the system stops, being empty and ready for a new set.</p>
	<p>Edit button Gives access for editing a job.</p>		<p>Save button Save the job or changes that have been made to a job.</p>

High Capacity Document Feeder (HCDF)

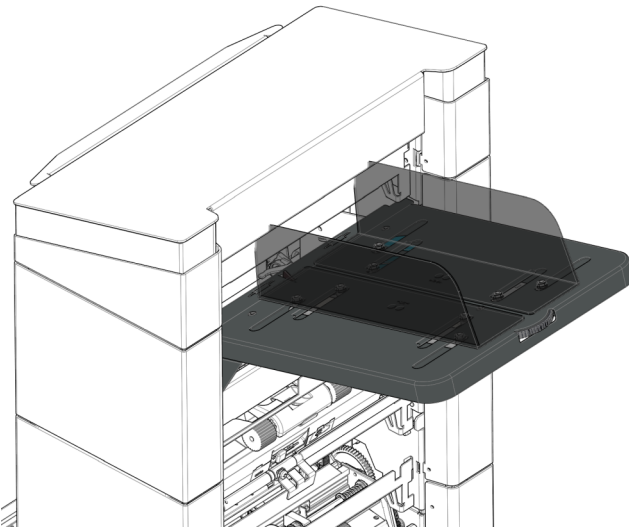

The High Capacity Document Feeder (HCDF) is an option that can be delivered from factory. The High Capacity Document Feeder has a capacity for up to 725 sheets. The normal document feeder tray has a capacity of 325 sheets.

For more information on the operation of the HCDF, refer to the topic on [loading documents for the HCDF](#) on page 67.

MaxiFeeder

The maxiFeeder is a feeder that can be loaded with a high number of documents. This feeder is intended to be used for Business Reply Envelopes (BRE), but also 'standard' documents up to 356 mm (14") length can be processed with it.

For more information on the operation of the maxiFeeder, refer to the topic on [loading documents for the maxiFeeder](#) on page 61.



A license is required if you want to use the maxiFeeder.

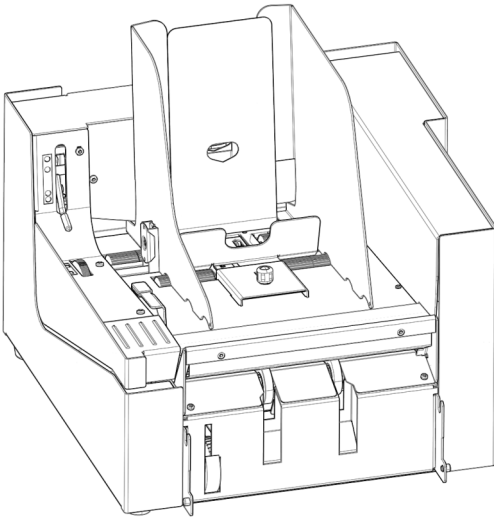

The versaFeeder is used to feed booklets, regardless of the thickness of the cover, to the document flow from the feeder to the inserter. Because of the location of the versaFeeder (downstream the feeder module) documents fed by the versaFeeder will not be folded.

When the versaFeeder is added to the configuration, this is shown in the screens at the operator panel.

For more information on the operation of the versaFeeder, refer to the topic on [loading documents for the versaFeeder](#).

High Capacity Conveyor Belt

The high capacity conveyor belt is designed for envelope transport from the inserter or franking device. The conveyor belt has two operation modes:

- The belt moves continuously.
- The belt moves in intervals. The belt moves about 45 mm (1.7 inch) each time a sensor detects the passage of an envelope.



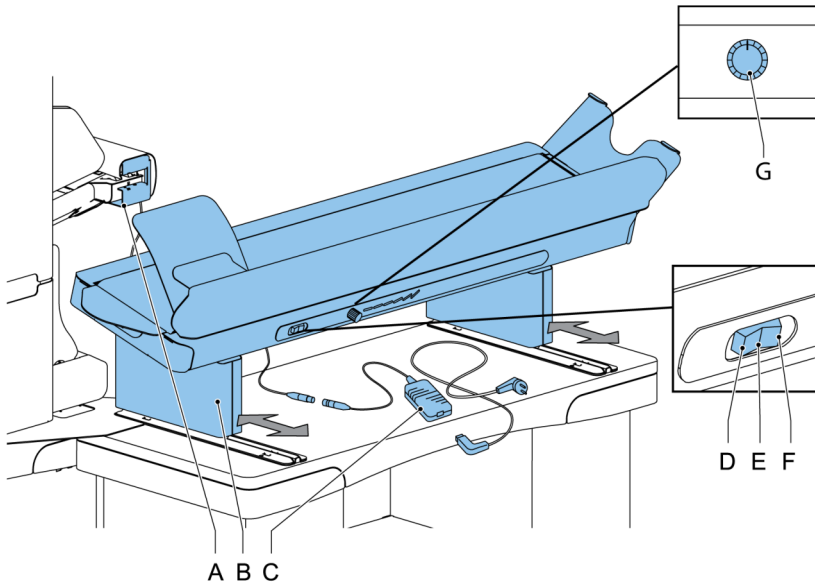

The guide plate and side guides prevent the envelopes from falling off the belt.

The conveyor belt switch has three positions:

- Mode **D**: the belt moves in intervals.
- Mode **E**: the belt is switched off.
- Mode **F**: the belt moves continuously.



With the turning knob (**G**) it is possible to set the interval distance between envelopes on the conveyor belt. The distance depends on the type of job and preference of the user.

(G)	Guideline:
	Minimal interval distance: 15 mm, setting for a job with thin envelopes. 
	Neutral interval distance: 20 mm
	Maximal interval distance: 40 mm, setting for a job with thick envelopes. 

Catch Tray for Side Exit

3

English



For stacking envelopes leaving from the side exit a catch tray can be mounted. You can select the catch tray in the Output settings tab of the job definition (see [Exit settings](#)).

Instead of a catch tray at the right hand (RH) side of the system it is also possible to install a catch tray on the left hand (LH) side. To achieve this it is necessary to reverse the side exit of the Stacker from RH to LH. Contact your supplier for more information about this option.

Power Stacker Support

Depending on the inserted type and amount of documents, the filled envelopes may get stack fan-shaped at the stacker.

To prevent this, an optional power stacker support can be used in order to stack the envelopes correctly.

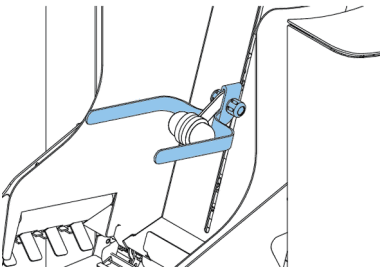

Shut Down the System

1. Press the **[On/Off]** button to shut down the system.



In case the system is unresponsive or fails to switch off, press and hold the touch sensitive power button for 10 seconds to switch off the system.

When the system is busy, it completes and inserts the current set, stops and will be shut down.
