

- Shift the envelope support in or out. The top side of the envelope must touch the dotted line on the support.

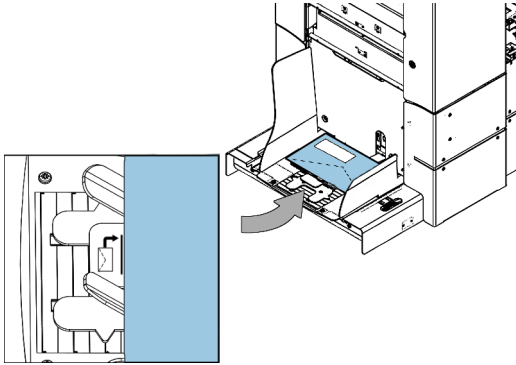

- Turn the envelope support to distribute the weight of the envelopes evenly on both sides.

Filling the Sealing Liquid Reservoir

When you want to seal envelopes, the sealing liquid reservoir must be filled.

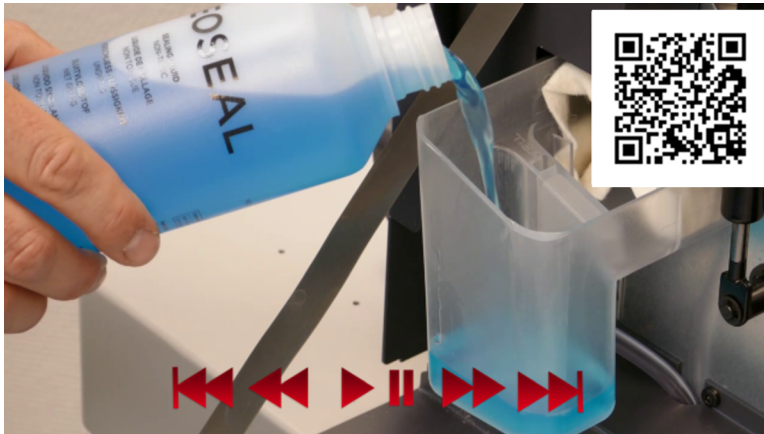

- Open the front cover A.

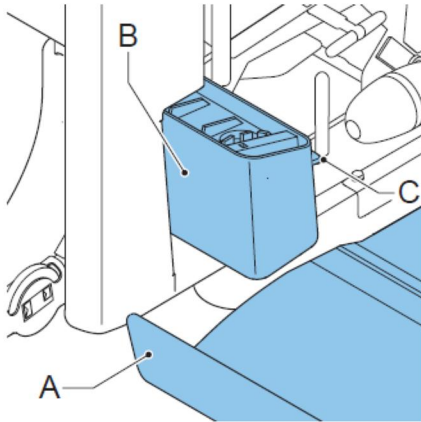

2. Fill the reservoir **B** up to lip **C** with sealing liquid.
3. Close the front cover **A**

Before you start the job, wait approximately 5 minutes for the brushes to moisten.

If the liquid reservoir is almost empty the touchscreen shows a message to warn you that you should refill the reservoir.
