

Version 1.0
March 2020
702P08306

Xerox® Adaptive CMYK Plus Technology for the Xerox® PrimeLink® C9065/C9070 Printer Accessory Reference Guide

©2020 Xerox Corporation. All rights reserved. Xerox®, Xerox and Design®, and PrimeLink® are trademarks of Xerox Corporation in the United States and/or other countries.

Adobe®, Adobe PDF logo, Adobe® Reader®, Adobe® Type Manager®, ATM™, Flash®, Macromedia®, Photoshop®, JobReady®, Illustrator®, InDesign®, and PostScript® are trademarks or registered trademarks of Adobe Systems, Inc.

Fiery® and PrintMe® are registered trademarks of Electronics For Imaging, Inc.

Table of Contents

1 Safety	5
Notices and Safety.....	6
Warning Symbols.....	7
Power Cord Safety Information.....	8
Vacuum Cleaner Use for Toner Spills	9
Printer Supplies.....	10
Powering Off the Printer.....	11
General Power Off.....	11
Powering Off the Main Power.....	11
2 Getting Started.....	13
Overview.....	14
Adaptive CMYK Plus Technology Options.....	15
Dedicated Toner Dispenser Assemblies.....	17
Dedicated Developer Drawer Assemblies.....	18
Cart	19
3 Replacing a Toner Kit	21
Replacing a Toner Kit	22
Setting the NVM Values.....	23
Powering Off the Printer.....	24
Removing the Toner Cartridges	25
Removing the Drum Cartridges	26
Removing the Toner Dispenser Assembly.....	27
Removing the Developer Drawer Assembly.....	28
Installing the Replacement Developer Drawer Assembly.....	29
Installing the Replacement Toner Dispenser Assembly.....	30
Reinstalling the Drum Cartridges.....	31
Installing the Replacement Toner Cartridges	33
Powering On the Printer	34
Evaluating Print Quality	35
4 Maintenance	37
5 Troubleshooting	39
General Print-Quality Problems and Solutions.....	40
Toner Cross-Reference Chart.....	42

Table of Contents

4	Xerox® Adaptive CMYK Plus Technology for the Xerox® PrimeLink® C9065/C9070 Printer Accessory Reference Guide
---	--------------------------------------------------------------------------------------------------------------

Safety

This chapter contains:

- Notices and Safety..... 6
- Warning Symbols 7
- Power Cord Safety Information 8
- Vacuum Cleaner Use for Toner Spills..... 9
- Printer Supplies 10
- Powering Off the Printer..... 11

For complete safety information, refer to the *Xerox® PrimeLink® C9065/C9070 Printer User Guide*. You can obtain documentation on the Xerox website at www.support.xerox.com/support. In the search field, enter PrimeLink C9065/C9070, then select the needed documentation.

Notices and Safety

Before operating your printer, read the following instructions carefully. Refer to these instructions to ensure the continued safe operation of your printer.

Your Xerox® printer and supplies are designed and tested to meet strict safety requirements. Safety requirements include safety agency evaluation and certification, and compliance with electromagnetic regulations and established environmental standards.

The safety and environment testing and performance of this product have been verified using Xerox® materials only.

For complete safety information, refer to the *Xerox® PrimeLink® C9065/C9070 Printer User Guide*. You can obtain documentation on the Xerox Website at www.support.xerox.com/support. In the Search or Choose field, enter PrimeLink C9065/C9070, then select the needed documentation.

Warning Symbols



This device is equipped with a strong permanent magnet that can interfere with medical device operation. Individuals with medical devices such as pacemakers should maintain a distance of 30 cm (12 in.) from this component.

Power Cord Safety Information

Before operating your printer, read the following instructions carefully. For details, contact your Xerox representative.



WARNING:

- The electrical supply for the device must meet the requirements stated on the data plate on the rear of the device. If you are not sure that your electrical supply meets the requirements, consult your local electricity provider or a licensed electrician.
- Do not use an extension cord.
- Do not remove or modify the power cord.

Refer to these instructions to ensure the continued safe operation of your printer.

- Use the power cord supplied with your printer.
- Plug the power cord directly into a properly grounded electrical outlet. Ensure that each end of the cord is connected securely. If you do not know if an outlet is grounded, ask an electrician to check the outlet.
- Do not use a ground adapter plug to connect the printer to an electrical outlet that does not have a ground connection terminal.



WARNING: Avoid the potential of electrical shock by ensuring that the printer is grounded properly. Electrical products can be hazardous if misused.

- Verify that the printer is plugged into an outlet that provides the correct voltage and power. Review the electrical specification of the printer with an electrician, if necessary.
- Do not place the printer in an area where people can step on the power cord.
- Do not place objects on the power cord.
- Replace the power cord if it becomes frayed or worn.
- Do not unplug or plug the power cord while the printer is powered on.
- To avoid electrical shock and damage to the cord, grasp the plug when unplugging the power cord.
- Ensure that the electrical outlet is near the printer and is easily accessible.

The power cord is attached to the printer as a plug-in device on the back of the printer. If it is necessary to disconnect all electrical power from the printer, disconnect the power cord from the electrical outlet. For details, refer to [Powering Off the Printer](#).

Vacuum Cleaner Use for Toner Spills

Use a broom or wet cloth to wipe off spilled toner. To minimize generation of dust particles, sweep or wipe slowly. Avoid using a vacuum. If you must use a vacuum, ensure that the unit is designed to contain combustible dusts. Ensure that the vacuum includes an explosion-rated motor and non-conductive hose.

Printer Supplies

- Store all supplies in accordance with the instructions given on the package or container.
 - Keep all supplies away from the reach of children.
 - Never throw toner, print cartridges, drum cartridges, or toner containers into an open flame.
 - When handling supplies, avoid skin and eye contact. Eye contact can cause irritation and inflammation.
 - Do not attempt to disassemble supplies, which can increase the risk of skin or eye contact.
-  **Caution:** Use of non-Xerox supplies is not recommended. The Xerox Warranty and the Service Agreement do not cover damage, malfunction, or degradation of performance caused by use of non-Xerox supplies, or the use of Xerox supplies not specified for this printer.

Powering Off the Printer

General Power Off

 **Note:** Before powering off the printer, wait 5 seconds after any active job completes.

To power off the device, press the power **On/Off** button. For general use, to power on and power off the printer, press the power **On/Off** button. Do not use the main power switch to power on and power off the printer unless required.

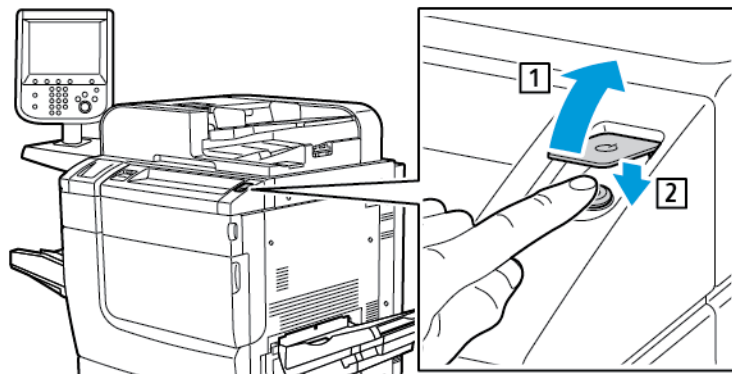

If you select the **Energy Saver** option, the printer enters an energy-saver mode immediately. If there are jobs in the print queue, a job status message appears.

 **Note:** To reactivate the printer when it is in Energy Saver mode, press the **Energy Saver** button.

Powering Off the Main Power

The main power switch controls the main power into the printer. For normal printer operation, leave the main power on. Before connecting a cable, cleaning the printer, or when a restart is required, press the main power switch to the Off position.

 **Caution:**

- Before unplugging the power cord, press the main power switch to the Off position. Failure to do so can damage the printer or cause a printer malfunction.
- After you power on the printer, wait a few seconds before you power off the main power. Failure to do so can damage the printer hard drive or cause a printer malfunction.
- After you press the printer On/Off power button, wait a few seconds before you press the main power switch to the Off position. Failure to do so can damage the printer hard drive or cause a printer malfunction. After you power off the printer, wait until the control panel touch screen goes dark. Wait 10 seconds, then press the main power switch to the Off position.

Safety

- While a job is processing, or while the Energy Saver button is blinking, do not press the main power switch. Doing so can damage the printer hard drive or cause a printer malfunction.

To power off the main power switch:

1. Open the front cover, then press the main power switch to the Off position.

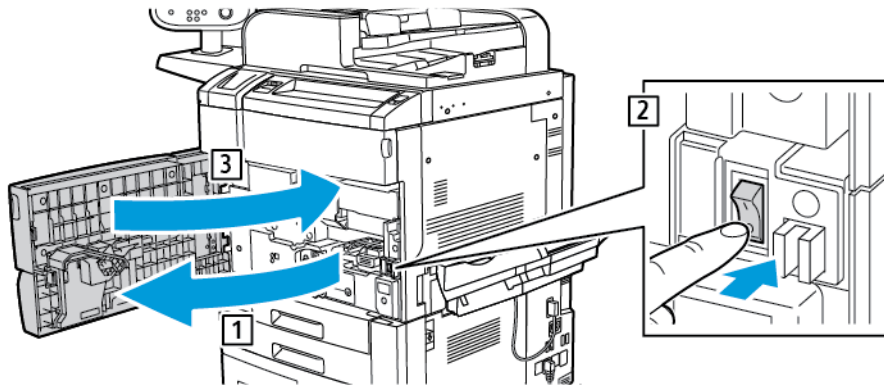

2. Close the front cover.

Getting Started

This chapter contains:

- Overview 14
- Adaptive CMYK Plus Technology Options..... 15
- Dedicated Toner Dispenser Assemblies..... 17
- Dedicated Developer Drawer Assemblies 18
- Cart 19

This reference guide is intended for trained users only.

Overview

The Xerox® Adaptive CMYK Plus Technology allows you to add new toner color options to your printer, in addition to the traditional black, cyan, magenta, and yellow.

Each Xerox® Adaptive CMYK Plus Technology kit consists of a unique set of toner cartridges, a toner dispenser assembly, a developer drawer assembly, and a cart.

Adaptive CMYK Plus Technology Options

Available specialty toner kits for a Xerox® PrimeLink® C9065/C9070 Printer with Adaptive CMYK Plus Technology:

Vivid Toner Kit, Order Number 097N02388
Cart
Dedicated toner dispenser assembly
Dedicated developer drawer assembly
Gold (GLD) toner
White (WHT) toner
Silver (SLV) toner
Clear (CLR) toner

Vivid and Fluorescent Combination Toner Kit, Order Number 097N02389
Cart
Dedicated toner dispenser assembly
Dedicated developer drawer assembly
Gold (GLD) toner
White (WHT) toner
Silver (SLV) toner
Clear (CLR) toner
Fluorescent Cyan (C-fl) toner
Fluorescent Magenta (M-fl) toner
Fluorescent Yellow (Y-fl) toner



Note: The cart, dedicated toner dispenser assembly, and dedicated developer drawer assembly are the same for each kit. If you have purchased the Vivid Toner Kit, and require the Combination Toner Kit, purchase the fluorescent specialty toners listed in the following table.

Available specialty toners for a Xerox® PrimeLink® C9065/C9070 Printer with Adaptive CMYK Plus Technology:

Specialty Toners for a Xerox® PrimeLink® C9065/C9070 Printer with Adaptive CMYK Plus Technology:	Order Number
Xerox® Gold Toner for Xerox® PrimeLink® C9065/C9070 Printer	006R01802
Xerox® White Toner for Xerox® PrimeLink® C9065/C9070 Printer	006R01803
Xerox® Silver Toner for Xerox® PrimeLink® C9065/C9070 Printer	006R01804
Xerox® Clear Toner for Xerox® PrimeLink® C9065/C9070 Printer	006R01805

Getting Started

Specialty Toners for a Xerox® PrimeLink® C9065/C9070 Printer with Adaptive CMYK Plus Technology:	Order Number
Xerox® Fluorescent Cyan Toner for Xerox® PrimeLink® C9065/C9070 Printer	006R01792
Xerox® Fluorescent Magenta Toner for Xerox® PrimeLink® C9065/C9070 Printer	006R01793
Xerox® Fluorescent Yellow Toner for Xerox® PrimeLink® C9065/C9070 Printer	006R01794

Dedicated Toner Dispenser Assemblies

To prevent cross-contamination of toners, each toner kit includes a dedicated toner dispenser assembly.



Dedicated Developer Drawer Assemblies

To prevent cross-contamination of toners, each toner kit includes a dedicated developer drawer assembly.



Cart

To store each toner kit, a custom cart is provided.



Replacing a Toner Kit

This chapter contains:

• Replacing a Toner Kit	22
• Setting the NVM Values	23
• Powering Off the Printer	24
• Removing the Toner Cartridges	25
• Removing the Drum Cartridges	26
• Removing the Toner Dispenser Assembly.....	27
• Removing the Developer Drawer Assembly.....	28
• Installing the Replacement Developer Drawer Assembly.....	29
• Installing the Replacement Toner Dispenser Assembly.....	30
• Reinstalling the Drum Cartridges.....	31
• Installing the Replacement Toner Cartridges	33
• Powering On the Printer	34
• Evaluating Print Quality	35

This chapter provides step-by-step instructions for replacing a toner kit in your Xerox® PrimeLink® C9065/C9070 Printer. Before you complete these steps, ensure that your printer is configured to support Xerox® Adaptive CMYK Plus Technology. For further information, contact Xerox Technical Customer Support.

Replacing a Toner Kit



Note: Use gloves for all procedures.

To replace a toner kit, perform each of the following procedures in the order provided.

1. [Setting the NVM Values](#)
2. [Powering Off the Printer](#)
3. [Removing the Toner Cartridges](#)
4. [Removing the Drum Cartridges](#)
5. [Removing the Toner Dispenser Assembly](#)
6. [Removing the Developer Drawer Assembly](#)
7. [Installing the Replacement Developer Drawer Assembly](#)
8. [Installing the Replacement Toner Dispenser Assembly](#)
9. [Reinstalling the Drum Cartridges](#)
10. [Installing the Replacement Toner Cartridges](#)
11. [Powering On the Printer](#)
12. [Evaluating Print Quality](#)

Setting the NVM Values

Before you install or change a specialty toner kit, assign the Non-Volatile Memory (NVM) values for each toner kit.

To assign the NVM values for each toner kit:

1. At the device control panel, log in as Administrator.
 - a. Press the **Log In/Out** button.
 - b. Type `admin`, then touch **Next**.
 - c. Type the administrator password, then touch **Enter**.
2. Press the **Machine Status** button, then touch the **Tools** tab.
3. Touch **System Settings**→**Common Service Settings**→**Maintenance**→**NVM Read/Write**.
4. To enter the NVM code 762–998, for Chain-Link, in the first box, type `762`. In the second box, type `998`. Touch **Confirm**.

The current NVM value appears.

5. For the toner kit that is being installed, for New Value, type 0–2 as appropriate, then touch **Save**. The values for the toners are listed as follows:
 - 0: Black, Cyan, Magenta, Yellow
 - 1: Gold, White, Silver, Clear (Vivid Toner Kit)
 - 2: Black, Flo-Cyan, Flo-Magenta, Flo-Yellow (Fluorescent Toner Kit)
6. To restart the printer, touch **Reboot Now**.

The printer restarts and accepts the new value.





Note: If there is a mismatch between the NVM setting and the installed toner kit, an error message appears. Verify that the NVM setting is correct for the installed toner kit. If the error message still appears, verify that the correct toner kit is installed.

Powering Off the Printer

 **Note:** Before powering off the printer, ensure that there are no active jobs.

1. Before powering off the printer, wait approximately 60 seconds to exit the power saver mode.
2. To power off the printer, press the **Power On/Off** button on the right side of the top front panel.
3. Before proceeding to the next step, wait for the power saver indicator to stop blinking.

 **Note:** To power off the printer, do not use the main power switch.

 **Caution:** Unplugging the power cord with the main power on can damage the printer internal hard drive or cause a printer malfunction.

 **Caution:** Powering off the main power immediately after powering on the main power can damage the printer internal hard drive or cause a printer malfunction.

 **Caution:** Powering off the main power immediately after pressing the Power On/Off button can damage the printer internal hard drive or cause a printer malfunction.

 **Caution:** Powering off the main power while a job is processing or while the Energy Saver indicator is blinking can damage the printer internal hard drive or cause a printer malfunction.

4. To power off the main switch, open the front door, then press the main power switch to the Off position.
5. Close the front door.
6. Disconnect the power cable from the electrical outlet to the printer.

Removing the Toner Cartridges

1. Before you remove any cartridges, protect the work area. Place paper on the floor so that any excess toner falls on the paper.
2. Open the toner cover above the printer front door.
3. Keep cartridge level and avoid touching the bottom of the cartridge.
4. To remove each cartridge, grasp the cartridge handle, then pull the cartridge straight out of the printer.



Caution: Be careful to not spill toner on your clothing or your surroundings.



WARNING: Never use a vacuum cleaner when you clean spilled toner. An explosion can occur as the toner fills the vacuum cleaner and creates sparks. To clean spilled toner, use a broom or a cloth moistened with a neutral detergent.

Removing the Drum Cartridges

! **Caution:** Do not expose drum cartridges to direct sunlight or strong light from indoor fluorescent lighting for more than 2 minutes. When the drum cartridges are exposed to light, image quality can deteriorate.

1. Leave the printer powered off. Open the front door.
2. To open the developer drawer, lower the R1–R4 latch, then hold the drawer handle and pull out the developer drawer until it stops.
3. To remove each drum cartridge, use the finger rings provided at both ends of the drum cartridge.
4. Carefully, lift each cartridge straight up and out of the printer.



5. Store the drum cartridges in a clean, covered, and dark area. The drum cartridges are reinstalled later in the procedure.

Removing the Toner Dispenser Assembly

1. Leave the printer powered off and keep the front door open.
2. For easy access to the toner dispenser assembly, slide the developer drawer halfway into the printer.
3. To access the toner dispenser assembly, lower the toner door.
4. To remove the toner dispenser assembly, grasp both sides, and pull the assembly out of the printer.



5. Store the toner dispenser assembly inside the cart.

Removing the Developer Drawer Assembly

1. To remove the developer drawer assembly, slide out the developer drawer until it stops.



Caution: Be careful to not spill toner on your clothing or your surroundings.

2. Using both hands, lift the developer drawer assembly out of the rail assembly.

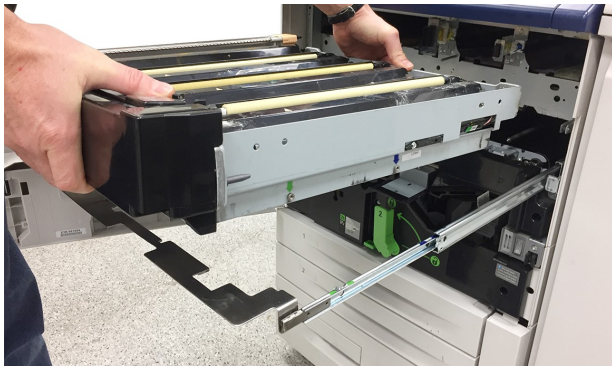

3. Place the developer drawer assembly inside the cart, using the built-in rails, on the same shelf where you placed the corresponding toner dispenser assembly.



Installing the Replacement Developer Drawer Assembly

1. From the cart, remove the developer drawer assembly associated with the required toner kit.
2. Hold the developer drawer assembly above the rail assembly and line up the arrow guides on the drawer frame to the slots on the rail assembly.

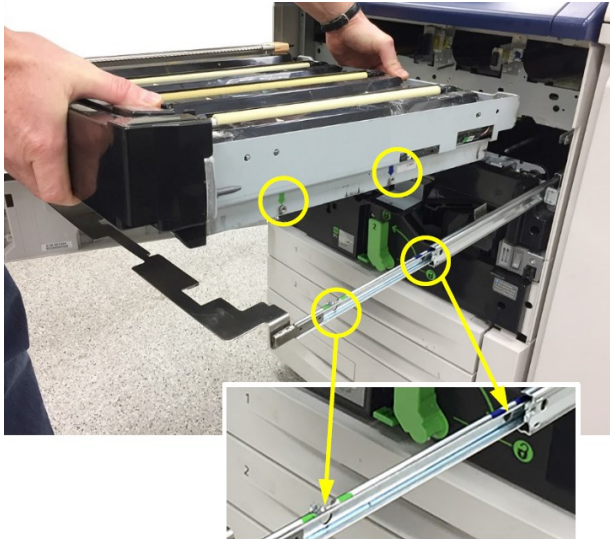

3. Lower the developer drawer assembly into position on the rail assembly.
4. Push the developer drawer into the printer until the developer drawer clicks into place.



Tip: The click sound indicates that the developer drawer is seated properly inside the printer.

Installing the Replacement Toner Dispenser Assembly

1. For easy access to the printer frame, pull out the developer drawer assembly approximately 254 mm (10 in.).
2. From the cart, remove the toner dispenser assembly for the required toner kit.
3. Open the toner assembly door, then slide the toner dispenser assembly into the printer and push the assembly firmly into place.



4. Close the toner cover.

Reinstalling the Drum Cartridges

1. Pull out the developer drawer fully.
2. For each drum cartridge housing, pull back the housing cover and remove the protective tab.



3. The drum cartridges have labels that indicate the front and the back of the cartridge. Align the front of the drum cartridge with the front of the developer drawer, and place the cartridge in the drawer.



! **Caution:** When you remove the cartridges from the packaging, do not touch or scratch the surface of the drum cartridges.

! **Caution:** When the drum cartridges are exposed to light, image quality can deteriorate.

4. To ensure that the drum cartridges are seated fully, press down both ends of the drum cartridges.

Replacing a Toner Kit

5. Push the developer drawer into the printer until the developer drawer clicks into place, then lower the drawer handle and lift the R1–R4 latch to secure the drawer in place.



Tip: The click sound indicates that the developer drawer is seated properly inside the printer.

6. Close the printer door.

Installing the Replacement Toner Cartridges

1. Open the toner cover above the printer front door.
2. From the cart, remove the required toner cartridges from the toner kit.
 - ⚠ **Caution:** Do not mix toner cartridges from different specialty toner kits. Ensure that the correct toner cartridges are installed for each kit. If the color toner cartridges are inserted incorrectly, the toner dispenser assembly becomes contaminated and a Service Call is required.
3. To insert each toner cartridge, hold the cartridge in both hands, and push the cartridge into the toner dispenser assembly until the cartridge clicks in place.



 **Note:** To ensure that the toner cartridges are installed in the correct positions, review the labels inside the toner door. Insert the correct toner cartridge color into the correct location in the printer.

4. Close the toner cover.
5. If the toner is spilled, clean the area using a damp cloth.

Powering On the Printer

! **Caution:** Powering on the main power immediately after powering off the main power can damage the printer internal hard drive or cause a printer malfunction.

1. Connect the power cable from the electrical outlet to the printer.
2. To power on the main printer power, open the front door, then press the main power switch to the On position.
3. Close the front cover.
4. To power on the printer, press the **Power On/Off** button on the right side of the top front panel.

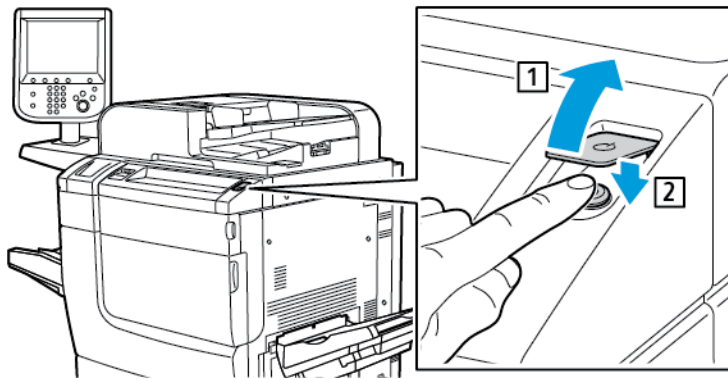

After the printer is powered on, a status message appears. The message is generated because the Vivid Toner Kit contains one gold toner starter cartridge. Print quality is not affected and you can continue to print. When a second gold toner cartridge is installed, the message does not appear.

Evaluating Print Quality

1. To evaluate the print quality, copy a test print, then ensure that the print is free of print defects.
2. As required, use the Adjust Image Transfer feature.

Replacing a Toner Kit

Maintenance

To clean any spilled toner, use a broom or a cloth moistened with a neutral detergent.



Caution: Be careful to not spill toner on your clothing or your surroundings.



WARNING: Never use a vacuum cleaner when you clean spilled toner. An explosion can occur as the toner fills the vacuum cleaner and creates sparks. To clean spilled toner, use a broom or a cloth moistened with a neutral detergent.

If you need any assistance for maintaining your printer:

- Visit the Xerox website at www.support.xerox.com/support. In the search field, enter PrimeLink C9065/C9070, then select the needed documentation.
- Contact Xerox Technical Customer Support.

Troubleshooting

This chapter contains:

- [General Print-Quality Problems and Solutions](#) 40
- [Toner Cross-Reference Chart](#)..... 42

General Print-Quality Problems and Solutions

Use the following table to find solutions to print-quality problems.

Problem	Solution
<p>Smears, smudges, and streaks: Dark or light marks appear on your output.</p>	<p>To remove toner that has accumulated on the fuser, run a print job that consists of several blank pages.</p> <p>If the problem persists, to help determine which component is causing the image-quality problem, print the test pages.</p> <ul style="list-style-type: none"> • If the defect occurs in one color only, replace the corresponding imaging unit. • If the defect occurs in all colors and is visible on all the test pages, replace the fuser.
<p>Repeating spots or lines: Spot or lines appear at regular intervals on the prints.</p>	<ol style="list-style-type: none"> 1 To identify the part responsible for the repeating spots or lines, measure the intervals between the marks or spots. 2 To correct the problem, replace the printer part identified by the interval.
<p>Colors look wrong: Colors do not look accurate or look drastically wrong.</p>	<ol style="list-style-type: none"> 1 Ensure that you have installed the correct toner dispenser assembly and developer drawer. 2 Perform the Calibrate Color procedure.
<p>Colors are too light or too dark: The print or color density is too light, missing, or the background is foggy.</p>	<ol style="list-style-type: none"> 1 Verify that the paper that you are using is the correct type for the printer and that the paper is loaded properly. 2 Verify that the paper loaded in the tray matches the paper type selected at the control panel and in the print driver. 3 To maximize the printed image quality, adjust your 2nd Transfer setting. 4 Your application or incorrect settings in the print driver can cause the print-quality problems.

Problem	Solution
<p>Toner is missing or easy to rub off: Toner appears to be missing from the print or is easy to rub off.</p>	<ol style="list-style-type: none"> 1 Verify that the paper that you are using is the correct type for the printer and that the paper is loaded properly. 2 Calibrate the paper type. 3 Raise or lower the fuser temperature setting. 4 At the control panel, select a heavier paper. <p> Note: Papers from lightest to heaviest are:</p> <ul style="list-style-type: none"> • For uncoated paper: Plain, Lightweight Cardstock, Cardstock, and Heavyweight Cardstock • For coated paper: Lightweight Glossy Cardstock, Glossy Cardstock, and Heavyweight Glossy Cardstock.
<p>Error message indicates that there is a mismatch between the NVM setting and the toner kit installed.</p>	<ol style="list-style-type: none"> 1 Verify that the NVM setting is correct for the toner kit installed. For details, refer to Setting the NVM Values. 2 If the NVM setting is correct and the message still appears, verify that the correct toner kit is installed.

Toner Cross-Reference Chart

Toner Kit	Position 1	Position 2	Position 3	Position 4	Position 5
Standard	Black 1	Black 2	Cyan	Magenta	Yellow
Vivid		Gold (GLD)	White (WHT)	Silver (SLV)	Clear (CLR)
Fluorescent	Black 1	Black 2	Fluorescent Cyan (C-fl)	Fluorescent Magenta (M-fl)	Fluorescent Yellow (Y-fl)

